

PL-2-445 | PL-5-445

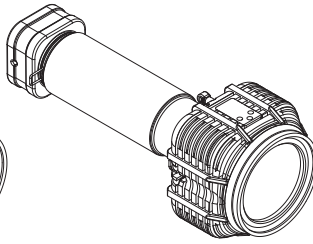

PL-9-445

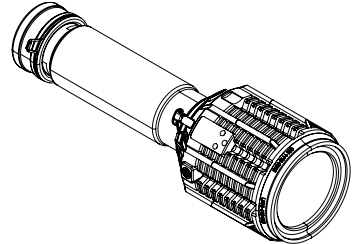

PL-410-445 | PL-445-520
PL-3-525

PL LASER SERIES

PL-2-445 | PL-5-445 | PL-3-525 | PL-9-445 | PL-410-445 | PL-445-520

PRODUCT MANUAL

TABLE OF CONTENTS

INTRODUCTION

Reference Guide	3
Models	4
Warnings	4
Physical Characteristics	5

OPERATION

Usage Ranges	6
Operational Modes	7

BATTERY INFORMATION

Battery Life	8
Charging Batteries	8

CARE AND CLEANING	9
--------------------------	---

ACCESSORIES	9
--------------------	---

WARRANTY	9-11
-----------------	------

CONTACT FOXFURY	11
------------------------	----

PL LASER REFERENCE GUIDE

P/N PL-2-445, PL-5-445, PL-9-445, PL-3-525

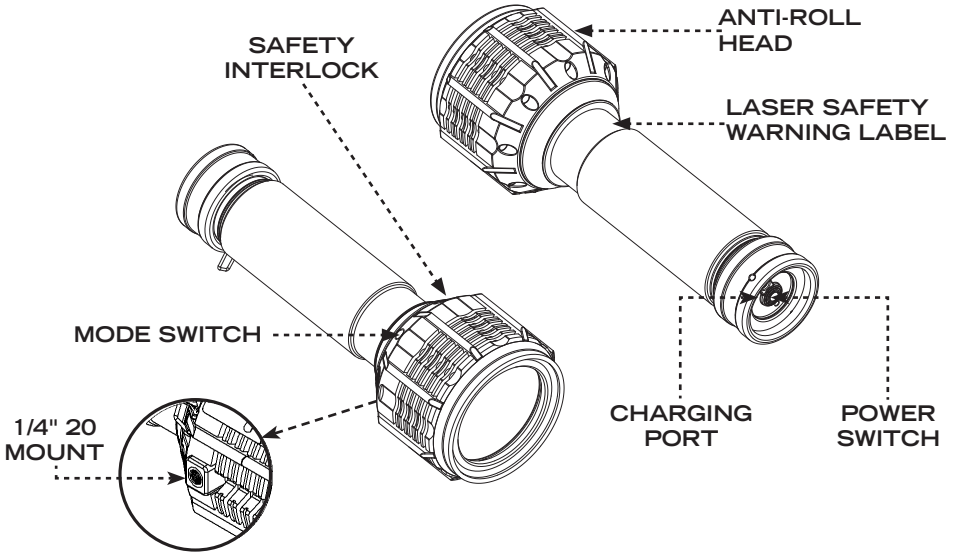

P/N PL-410-445, PL-445-520

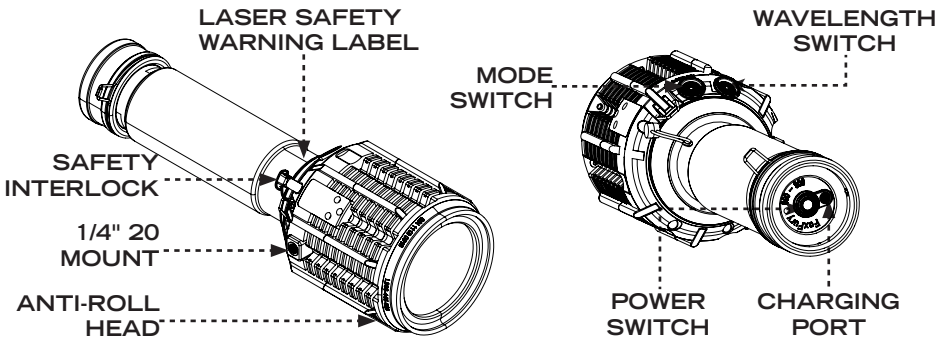

INCLUDED

- PL Laser
- AC Adaptor
- Carry Strap
- JOBY GorillaPod and Adaptor
- Laser Goggles
- Case

MODELS

Part Number	Product Name	Laser Goggles Included
PL-2-445	PL 445nm Blue 2W Forensic Laser System	Orange
PL-3-525	PL 525nm Green 3W Forensic Laser System	Orange, Yellow, Red
PL-5-445	PL 445nm Blue 5W Forensic Laser System	Orange
PL-9-445	PL 445nm Blue 9W Forensic Laser System	Orange
PL-410-445	PL Blue & Violet Forensic Laser System	Orange, Yellow
PL-445-525	PL Blue & Green Forensic Laser System	Orange, Yellow, Red

Please read below before using the PL Forensic Laser System as it relays beneficial operating and safety information.

WARNINGS

 Please fully charge the PL Forensic Laser before using it for the first time.

 When used for extended periods of time the Light Head may become HOT to the touch. Please use care when operating.

LASER SAFETY INFORMATION



For the safe use of Laser, please read and follows the warnings on page 9 - 11.

PHYSICAL CHARACTERISTICS

PL 445NM BLUE 2W FORENSIC LASER PL 445NM BLUE 5W FORENSIC LASER

DIMENSIONS	Length: 11.1 in (282 mm) Handle Diameter: 2.1 in (53 mm) Head Diameter: 3.8 in (97 mm)
WEIGHT	4.1 lbs (1.9 kg)

PL 445NM BLUE 9W FORENSIC LASER

DIMENSIONS	Length: 11.1 in (282 mm) Handle Diameter: 2.1 in (53 mm) Head Size: 3.8 in (97 mm)
WEIGHT	4.7 lbs (2.1 kg)

PL 525NM GREEN 3W FORENSIC LASER

DIMENSIONS	Length: 12 in (305 mm) Handle Diameter: 2.1 in (53 mm) Head Diameter: 3.8 in (97 mm)
WEIGHT	4.6 lbs (2.1 kg)

PL BLUE & VIOLET FORENSIC LASER PL BLUE & GREEN FORENSIC LASER

DIMENSIONS	Length: 12 in (305 mm) Handle Diameter: 2.1 in (53 mm) Head Size: 3.8 in (97 mm)
WEIGHT	4.8 lbs (2.2 kg)

USAGE RANGES

For PL-2-445 and PL-5-445:

The typical usage range to the surface being investigated is 4 -12 in. (100 - 305 mm) but is useful for general search at up to 5 - 8 ft (1.5 - 4.6 m) or pattern photos at up to 30 ft (9 m) with fluorescent reactant aid.

For PL-9-445:

The typical usage range to the surface being investigated is 10 - 15 in. (254 - 381 mm) but is useful for general search at up to 5 - 15 ft (1.5 - 4.6 m) or pattern photos at up to 30 ft (9 m) with fluorescent reactant aid.

For PL-3-525:

The typical usage range to the surface being investigated is 10 - 15 in. (254 - 381 mm) but is useful for general search at up to 5 - 8 ft (1.5 - 2.4 m) or pattern photos at up to 30 ft (9 m) with fluorescent reactant aid.

For PL-410-445:

The typical usage range to the surface being investigated is 10 - 15 in. (254 - 381 mm). The 410nm wavelength is useful for general search at up to 5 - 8 ft (1.5 - 2.4 m), the 445nm wavelength is useful for general search at up to 5 - 15 ft (1.5 - 4.6 m), or pattern photos at up to 30 ft (9 m) with fluorescent reactant aid.

For PL-445-520:

The typical usage range to the surface being investigated is 10 - 15 in. (254 - 381 mm). The 520nm wavelength is useful for general search at up to 5 - 8 ft (1.5 - 2.4 m), the 445nm wavelength is useful for general search at up to 5 - 15 ft (1.5 - 4.6 m), or pattern photos at up to 30 ft (9 m) with fluorescent reactant aid.

OPERATIONAL MODES

For P/Ns PL-2-445, PL-5-445, PL-9-445, PL-3-525:

	PL-2-445	PL-5-445	PL-9-445	PL-3-525
MODE	BLUE	BLUE	BLUE	GREEN
1	1 Watt	1 Watt	1 Watt	1 Watt
2	2 Watt	2 Watt	3 Watt	2 Watt
3	N/A	3 Watt	5 Watt	3 Watt
4	N/A	5 Watt	9 Watt	N/A

For P/Ns PL-410-445, PL-445-520:

	PL-410-445		PL-445-520	
MODE	BLUE	UV	BLUE	GREEN
1	3 Watt	1 Watt	3 Watt	1 Watt
2	6 Watt	2 Watt	6 Watt	2 Watt
3	9 Watt	3 Watt	9 Watt	3 Watt

- 1 Insert the Safety Interlock.
- 2 Press the Power Switch located at the base of the Laser to turn it on.
 - For S/N 0880, 0881, 0884 and up, Safety Interlock will flash red while laser is turned on and in operation.
 - For P/N PL-410-445 & PL-445-520, press the Wavelength Switch located on the Light Head to choose the Wavelength.
- 3 Press the Mode Switch to change the mode.
- 4 Press the Power Switch to turn it off.

NOTE:

- After the Laser is powered off, it will not retain the mode in memory and will start again at Mode 1 when powered back on; this insures additional safety from accidental over exposure, as well as lower power to be used at short distances
- Lasers are equipped with thermal protection that may shut off during prolonged use. The unit will be able to turn back on when allowed to cool down.

BATTERY INFORMATION

BATTERY LIFE

P/N	BATTERY LIFE*
PL-2-445	2 - 2.5 hours
PL-5-445	50 - 60 minutes
PL-9-445	35 - 40 minutes
PL-3-525	50 - 60 minutes
PL-410-445	50 - 60 minutes
PL-445-520	50 - 60 minutes

*Battery life may vary according to capacity or age of the charged battery, mode and ambient conditions.

CHARGING THE BATTERIES

- The PL Forensic Laser is rechargeable. The Battery takes approximately 4 hours to charge fully.
- The AC adaptor has an LED indicator which turns GREEN when plugged into an outlet. As soon as you connect it to the PL for charging, the indicator turns RED. Once fully charged, the indicator turns to solid GREEN.
- The Charging Indicator on the PL turns GREEN when the AC adaptor plug is inserted into the Charging Port. This function advises that the PL is attempting to charge.

WARRANTY AND OTHER INFORMATION

PRODUCT DURABILITY



3 M



1 M



IPX7



Meets NFPA Standards

Operational Temperature: -10° to 40° C
(14° - 104° F)

CARE/CLEANING

Your PL Forensic Laser System is a professional tool. Regular maintenance and care of your light will maximize performance for you. As needed, wash your Laser using a soft washcloth, clean water and a mild soap. Be sure that all parts are reassembled securely before washing. When done, pat dry with a damp cloth.

AVAILABLE ACCESSORIES

- ❖ Carry Strap, P/N 600-100
- ❖ Case, P/N 80-001
- ❖ Laser Goggles OD 7+ Orange, P/N 600-1050
- ❖ Laser Goggles OD 6+ Yellow, P/N 600-1060
- ❖ Laser Goggles OD 5+ Red, P/N 600-1070
- ❖ CS Eye Laser Goggles, Orange & Yellow, P/N 600-1160
- ❖ CS Eye Laser Goggles, Yellow & Orange, P/N 600-1170

WARNINGS

FoxFury, LLC is not responsible for the incorrect use of any FoxFury Lighting product.

- ❖ Always operate the PL Laser with appropriate goggles.
- ❖ Lights are strong enough to cause damage to the human eye.

- ❖ Do not stare in Laser for long periods of time or from a close range shorter than the NOHD defined.
- ❖ Do not look directly into the Laser light during operation, even for a brief period. This can be harmful to the eyes due to the intensity of the Laser light and short range.
- ❖ The user should operate the Laser without wearing any reflective jewelry like watches, rings, bracelets, etc. that could send reflections back to the user's eye.
- ❖ Avoid touching the head of the Laser. It may get very warm or hot. Rubber insulators have been strategically installed to protect the user and to protect the surfaces where the Laser will be placed.
- ❖ The PL Laser is heavy. If the Laser falls, it may cause injury to people or objects. Footwear that covers the toes should be worn in the area where this tool is used.
- ❖ FoxFury, LLC is not responsible for any injury or damage caused during the use of this product.
- ❖ Do not use under the influence of drugs or alcohol.

EYE & SKIN SAFETY RANGES

- **Nominal Ocular Hazard Distance (NOHD): Safest more than 48 in. (1.2 m) from eyes**
- **Nominal Skin Hazard Distance (NSHD): Safest more than 4 in. (101.6 mm) from skin**
- ***Nominal Ocular Hazard Area: 41 square feet (3.8 square meters). Persons in this area should be wearing Laser safety eyewear. This region is where the specular reflections from mirrors, chrome, and stainless steel surfaces (at**

any angle), and glossy plastic or laminate surfaces at low angles can reflect the Laser beam with little diffusion.

- **Skin exposure at from 0.25 - 1 in. (6.35 - 25.4 mm) will feel painful in about 0.5 of a second. Expect a quick pain reaction and withdraw quickly from the beam.**

LASER SAFETY

Output beam is classified at Class 3B.

A Class 3B Laser is hazardous if the eye is exposed directly, but diffuse reflections such as those from paper or other matte surfaces are not harmful. The AEL for continuous Lasers in the wavelength range from 315 nm to far infrared is 0.5 W. For pulsed Lasers between 400 and 700 nm, the limit is 30 mJ. Other limits apply to other wavelengths and to ultra-short pulsed Lasers. Protective eyewear is typically required where direct viewing of a class 3B Laser beam may occur.

As an example, Class 3B Lasers are used inside CD and DVD writers, although the writer unit itself is Class 1 because the Laser light cannot leave the unit. But technicians that work on the inside of the units, must wear Laser safety eyeglasses.

Five Class-4 Lasers are used to create the homogeneous output beam, free of the normal interference patterns and speckle that direct Laser beams (like Laser pointers) can create upon reflection or backscatter. The beam diffusers greatly attenuate the output beam power and allow them to be mixed on target.

The Class-4 Lasers are equipped with a safety plug-key and a set of tamper-proof screws. The safety key must be removed to disconnect power if unit is opened for inspection, cleaning, or maintenance, by factory certified technicians.

The typical user should have no reason to open the front section of the Laser-light, please leave that to experienced technicians with the proper tools and

protections available.

It is recommended that the safety plug-key have a removable clasp feature added (like for your car keys) so that the safety plug-key can be easily separated from the Laser.

The safety plug-key, allows the operator to "safe" the Laser, if they need to leave the unit on-scene and take a break, or use the restroom; by taking the key with them - to protect the curious from themselves.

Eye protection is strongly recommended when using this product.

The user should operate the Laser without wearing any reflective jewelry, like watches, rings, or bracelets, etc. that could send reflections back to the user's eye.

LIMITED LIFETIME WARRANTY

FoxFury, LLC ("FoxFury") warrants this product to be free from defects in material for a lifetime of use except for batteries, LEDs, abuse, and normal wear. Mechanical components subjected to constant deformation or action, like springs and switches, and electronic components including chargers and LEDs are warranted for a period of two years from the time of purchase. FoxFury will repair or replace a product should it be determined defective.

Rechargeable batteries are consumable items, and carry a pro-rated 2 year warranty. Example: If a problem arises after one year of use, only 50% of the replacement cost will be charged, as long as the batteries are verified to have been charged, stored, and used in accordance with required practices.

This limited lifetime warranty is given only to the original end user of

the accompanying product. If you purchased a product from someone other than an authorized FoxFury reseller/distributor or if the product was used, (including but not limited to demo models, show models or refurbished product by someone other than FoxFury) prior to your purchase, you are not the Original Purchaser and the product that you purchased is not covered by this warranty. This limited warranty is VOID if this Product has been altered or modified in any way (including but not limited to attempted warranty repair without authorization from FoxFury and/or alteration/removal of the serial number). To expedite warranty concerns, we encourage the end user to register their FoxFury Product at www.foxfury.com/pages/warranty-registration.

THIS IS THE ONLY WARRANTY,
EXPRESSED OR IMPLIED,

INCLUDING ANY WARRANTY OF
MERCHANTABILITY OR FITNESS
FOR A PARTICULAR PURPOSE.
INCIDENTAL, CONSEQUENTIAL
OR SPECIAL DAMAGES ARE
EXPRESSLY DISCLAIMED EXCEPT
WHERE SUCH LIMITATION IS
PROHIBITED BY LAW.

You may have other specific legal rights which vary by jurisdiction. Go to www.foxfury.com/pages/warranty for a complete copy of the warranty. Retain your receipt for proof of purchase.

CONTACT FOXFURY

FoxFury, LLC

Oceanside, CA 92056 USA

Tel: 760.945.4231

Email: service@FoxFury.com

Web: FoxFury.com

All FoxFury products are designed in Oceanside, CA. All FoxFury products are manufactured with the highest quality USA and foreign parts. Products are assembled in either FoxFury's controlled plant in Asia or the USA, under strict quality control.

CALIFORNIA PROPOSITION 65

This product can expose you to chemicals including Lead and DEHP, which are known to the State of California to cause cancer and birth defects or other reproductive harm. For more information go to www.P65Warnings.ca.gov.

